

Operation

NO Normally Open



NO or NC rotating the sensor

NC Normally Closed



Typical connection to contactor

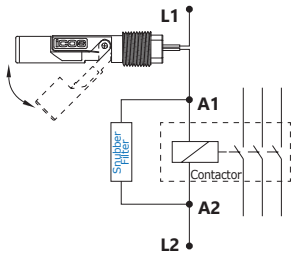

Switch **NO/NC - SPST**
Output **Contact ON/OFF**
Enclosure Rating **IP66**

! Never connect the sensor to a motor, pump, lamp or any other load over 20W. Always use a contactor or relay.

The sensors work in all voltage and current ranges displayed in the table below:

Operating Voltage	Max. Switching Power	Max. Switching Current	Peak Current
110Vac	20VA	0.2A	0.5A @20ms
220Vac	20VA	0.1A	0.5A @20ms
5Vdc	2.5W	0.5A	1A @20ms
12Vdc	5W	0.5A	1A @20ms
24Vdc	10W	0.5A	1A @20ms

24Vac: NOT recommended

Term of Warranty

For installations according to this guide: 02 (two) years warranty. **INCORRECT INSTALLATION CANCELS THE WARRANTY.** All sensors have been tested and approved during the manufacture process.

Chemical products require tests by the customer to verify compatibility with the constructive material of the sensor.

Liquids with ferrous particles require technical analysis: the sensor has magnetic component inside.

On datasheets.icos.us available technical specifications

+55 (15) 3032.9190

Electrical contact of sensors - Attention to install

Reed Switch 20W/VA: Protect the electrical contact of your sensor



Reed Switches are hermetically sealed contacts actuated by a magnetic field.

The life expectancy of a reed switch refers to a kind of load to be used. Reed Switches of the highest reliability are applied in our sensors, and their life expectancy can reach above two million operations. However, when they are switching lamps, inductive or capacitive loads, this number may decrease.

Switching Power

It is important to consider that the power specified by an electrical load is often referred to the permanent working state.

For higher power, use an auxiliary relay or contactor as recommended below.

Siemens 3RT1015 Contactor

Initial: 31.7VA
Rated: 5.1VA

Note: Reed Switches have reached over one million operations in tests with contactor and **K8*** snubber filter.

*On accessories.icos.us check models and prices of Filters

Level Switches

Manual: Models for External Mounting



IMPORTANT!
YOU MUST CHECK BEFORE INSTALLATION

Connection with cable length 20 to 40 meters:

For distances longer than 40m, use 24Vdc voltage (without the resistor)

Connection with:
- Timing Relay
- Frequency Inverter

For installation with Relay Coupler, use 4K7 10W resistor

Resistor 22R 5W in series is required



Resistor 220R 5W in series is required



Connection with Contactor 24Vdc

KD Filter is required



Connection with Contactor

Initial Power Rated Power

Should be less than **20W**

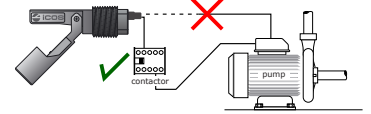

*For sale on accessories.icos.us

Questions? Call us **BEFORE** you install:

+55 (15) 3032.9190

levelsensor.icos.us | datasheets.icos.us | videos.icos.us

PROTECTION PROCEDURES BELOW DESCRIBED CAN IMPROVE THE REED SWITCH PERFORMANCE

• Switching inductive loads

K8* Filter mounted in parallel with the coil of an AC contactor, increases the contact life.

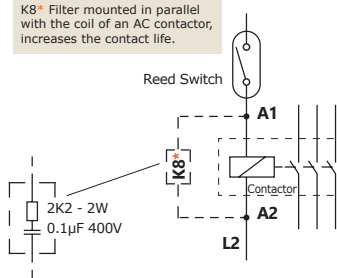

KD* Filter mounted in parallel with the coil of a DC relay, increases the contact life.

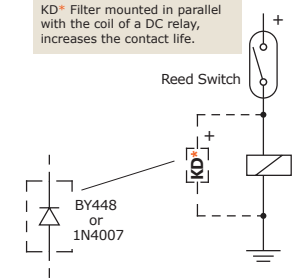

? Risk of failure (welding of the Reed Switch Contact) due to CAPACITANCE, which can occur depending on the distance and cable used in the connection to the contactor.

• Connecting the sensor to a contactor in long distances, use resistor:

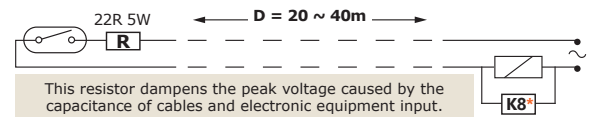

! Important: For distances **greater than 40m**, use 24Vdc voltage.

• Connecting the sensor to an electronic equipment:

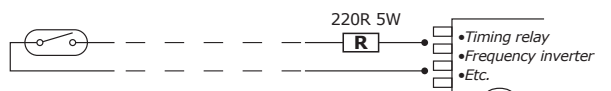

! Important: For installation with **relay coupler**, use 4K7 10W resistor.

External Side Mounting

With 1/2"NPT Thread



- Electrical contact: Reed Switch 20W/VA;
- Mounting: 1/2"NPT thread;
- Sealing: Sealant tape;
- NO or NC, by rotating the sensor 180°.

Technical Specifications	LA12N-40	LA22N-40	LA32N-40	LA32-M12
Material	POM	PP	PPA	PPA
Operating temperature range	-10°C to 100°C	-10°C to 100°C	-10°C to 125°C	-10°C to 125°C
Maximum operating pressure	2bar	2bar	2bar	2bar
Color	White	Dark blue	Black	Black
Liquid minimum density (SG)	0.76	0.68	0.70	0.70
Output connection	40cm cable	40cm cable	40cm cable	M12 plug

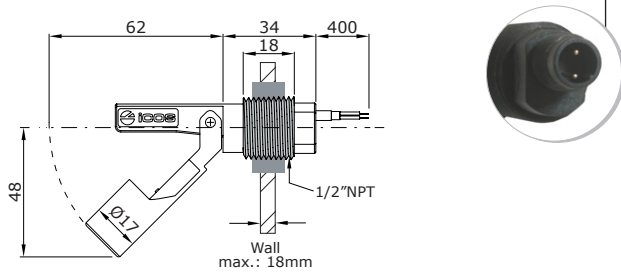

With Compression Gasket for Ø22mm Hole



- Electrical contact: Reed Switch 20W/VA;
- Mounting: In through hole of Ø22mm;
- Sealing: Compression gasket;
- NO or NC, by rotating the sensor 180°.

Technical Specifications	LA322E-40	LA322E-M12	LF322E-M12
Material	PPA	PPA	PPA
Operating temperature range	-10°C to 125°C	-10°C to 125°C	-10°C to 125°C
Maximum operating pressure	2bar	2bar	2bar
Color	Black	Black	Black
Liquid minimum density (SG)	0.70	0.70	0.66
Sealing (rubber type)	NBR	NBR	EPDM
Output connection	40cm cable	M12 plug	M12 plug

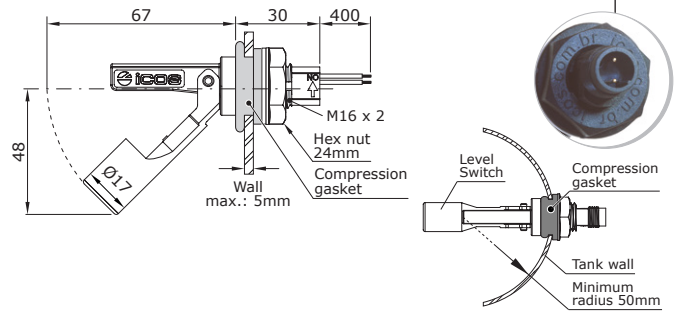

With M12 Plug + 1"NPT Thread



- Electrical contact: Reed Switch 20W/VA;
- Mounting: 1"NPT thread;
- Vedação: Sealant tape;
- NO or NC, by rotating the sensor 180°.

Technical Specifications	LA31N-M12
Material	PPA
Operating temperature range	-10°C to 125°C
Maximum operating pressure	2bar
Color	Black
Liquid minimum density (SG)	0.70
Output connection	M12 plug

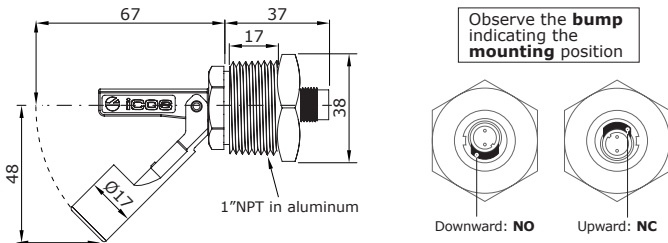

M12 Plug Sensors Installation

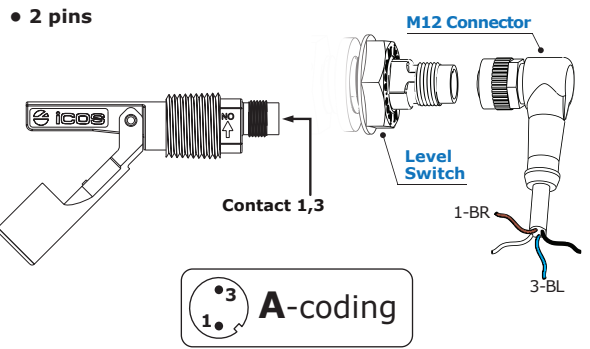

Constructive Materials

- POM Polyacetal:** Ideal for water, fuels and lubricants.
- PP Polypropylene:** Ideal for chemical products. **NOT suitable for fuel.**
- PPA Polyphthalamide:** Best mechanical and temperature resistance.

With DIN 43650 Output Connection



- Electrical contact: Reed Switch 20W/VA;
- Mounting: 1/2"NPT thread;
- Vedação: Sealant tape;
- NO or NC, by rotating the sensor 180°.

Technical Specifications	LA32NP
Material	PPA
Operating temperature range	-10°C to 125°C
Maximum operating pressure	2bar
Color	Black
Liquid minimum density (SG)	0.70
Output connection	DIN 43650

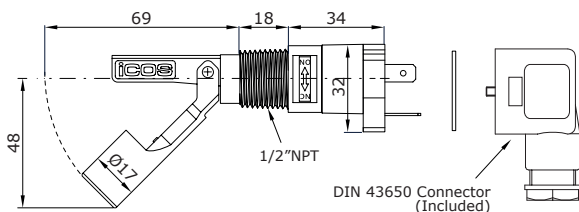

With Extra 1/2"NPT Thread for Conduit or Connection Head



- Electrical contact: Reed Switch 20W/VA;
- Mounting: 1/2"NPT thread;
- Vedação: Sealant tape;
- NO or NC, by rotating the sensor 180°.

Technical Specifications	LA32N2-40
Material	PPA
Operating temperature range	-10°C to 125°C
Maximum operating pressure	2bar
Color	Black
Liquid minimum density (SG)	0.70
Output connection	40cm cable

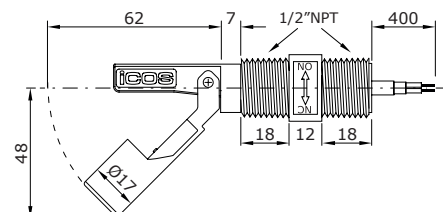

Dimensions in millimeters